

Make-up unit, full fresh air

With return/exhaust and thermodynamic heat recovery
Reversible heat pump technology
Indoor or outdoor installation

**Air flow rate from 278 to 3900 l/s
from 1000 to 16000 m³/h)**



ZEPHIR³

ZEPHIR³ encases the entire primary air system in a single packaged system. It extracts stale air and purifies outdoor air through the high efficiency **electronic filters**, effective against nanoparticles, PM10, bacteria and pollen.

- ▶ The **active thermodynamic recovery**, based on the reversible heat pump technology, exploits stale as thermal source. It features high energy efficiency, thanks to the **variable capacity compressor** and the electronically controlled fans with variable flow capability. This way, it also gets rid of the major consumption due to high pressure drops from passive recovery units. The capacity from the thermodynamic circuit replaces most of the power produced by heating and cooling stations, without fossil fuels and no need for fluid distribution pipework.
- ▶ ZEPHIR³ eliminates components with no useful effect, such as storage tanks, pipes and pumps, also thanks to the **free reheating** with hot gas recovery. Built-in controls allow operation with **constant supply temperature, at maximum available capacity, at high airflow**.
- ▶ As it can greatly reduce primary energy consumption and CO₂ emissions, ZEPHIR³ increases the property value and makes it easier to access financial support.
- ▶ It sets industrial standards as it eliminates 80% of the on site work, with amazing savings on the Total Life Cycle Cost. Being the core equipment in residential, commercial and industrial applications, it can be matched to fan coils, direct expansion and VRF systems, radiant systems and chilled beams, raising efficiency in existing buildings as well.

functions and features



Heat pump



Air cooled



Indoor installation



Outdoor installation



R-410A



Hermetic Scroll
(sizes Size 2÷Size 6)



Hermetic Rotary
(Size Size 1)



FREE-COOLING



Active
thermodynamic
recovery



Electronically
commutated
Plug Fan



Electronic expansion
valve



Full Inverter DC



Constant Air Volume



Variable Air Volume

dimensions and clearances

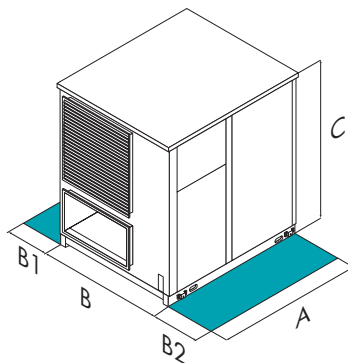

Size – CPAN-XHE3		Size 1	Size 2	Size 3	Size 4	Size 5	Size 6
A - Length	mm	1895	1895	2465	2465	2465	2465
B - Width	mm	950	950	1735	1735	2025	2330
C - Height	mm	1025	1625	1810	2260	2260	2260
B1	mm	700	700	700	700	700	700
B2	mm	1200	1200	1200	1200	1200	1200
Operating weight	kg	320	450	1070	1285	1450	1670

The above mentioned data are referred to standard units for the constructive configurations indicated. For all the other configurations, refer to the relative Technical Bulletin.

CAUTION! For trouble-free operation of the unit it is essential to maintain the safety distances indicated by the green areas.

versions and configurations

ENERGY RECOVERY:

► **RTA** Active thermodynamic recovery (Standard)

OPERATION:

► **RCM** Refrigeration circuit with capacity modulation (Standard)

RE-HEATING COIL:

► **CPHGM** Hot gas re-heating coil with capacity modulation (Standard)

UNIT INSTALLATION:

► **IO** Outdoor installation (Standard)
► **II** Indoor installation

technical data

Size – CPAN-XHE3		Size 1	Size 2	Size 3	Size 4	Size 5	Size 6
Operation with constant supply temperature							
Standard airflow							
Nominal air flow	l/s	361	611	1278	2000	2638	3333
Nominal air flow	m ³ /h	1300	2200	4600	7200	9500	12000
Max external static pressure (supply)	Pa	630	630	630	600	420	630
Max external static pressure (extraction)	Pa	630	630	630	630	540	630
Cooling							
Total cooling capacity	(1) kW	10,6	17,5	38,7	58,4	79,0	95,9
Re-heating capacity	(1) kW	2,74	4,23	11,0	15,2	21,7	23,4
Compressor power input	(1) kW	2,91	4,92	11,1	15,7	20,4	23,2
EER_C	(1) -	4,59	4,43	4,48	4,67	4,94	5,13
Heating							
Heating capacity	(2) kW	5,93	10,0	21,0	32,9	43,4	54,9
Compressor power input	(2) kW	0,71	1,23	2,54	4,22	5,75	8,77
COPc	(2) -	8,38	7,45	8,28	7,80	7,55	6,26
Operation at the maximum available capacity							
Standard airflow							
Nominal air flow	l/s	361	611	1278	2000	2638	3333
Nominal air flow	m ³ /h	1300	2200	4600	7200	9500	12000
Max external static pressure (supply)	Pa	630	630	630	600	420	630
Max external static pressure (extraction)	Pa	630	630	630	630	540	630
Cooling							
Total cooling capacity	(3) kW	10,6	17,5	38,7	58,4	79,0	95,9
Re-heating capacity	(3) kW	3,26	5,52	12,5	17,7	22,9	26,1
Additional available capacity to space	(3) kW	3,62	5,72	14,2	20,0	28,2	31,5
EER_C	(3) -	3,25	3,18	3,10	3,31	3,45	3,68
Heating							
Heating capacity	(4) kW	10,5	17,8	37,1	58,2	76,8	96,9
Compressor power input	(4) kW	2,28	3,77	7,10	11,2	14,4	18,3
COPc	(4) -	4,61	4,72	5,21	5,20	5,33	5,29
Operation with high airflow							
Maximum air flow							
Nominal air flow	l/s	528	972	1944	2556	3194	3889
Nominal air flow	m ³ /h	1900	3500	7000	9200	11500	14000
Max external static pressure (supply)	Pa	630	470	630	450	345	630
Max external static pressure (extraction)	Pa	630	630	630	530	400	630
Cooling							
Total cooling capacity	(5) kW	9,20	18,2	31,9	45,1	62,0	80,6
Compressor power input	(5) kW	1,56	3,38	4,46	6,97	13,8	17,8
EER_C	(5) -	5,89	5,38	7,15	6,48	4,50	4,51
Heating							
Heating capacity	(6) kW	6,00	11,1	22,1	29,1	36,3	44,2
Compressor power input	(6) kW	0,54	1,31	2,48	3,11	3,40	5,44
COPc	(6) -	11,1	8,46	8,94	9,36	10,7	8,14
Refrigeration circuits	Nr	1	1	2	2	2	2
No. of compressors	Nr	1	1	2	2	3	3
Type of compressors	(7) -	ROT	Scroll	Scroll	Scroll	Scroll	Scroll
Type of supply fan	(8) -	RAD	RAD	RAD	RAD	RAD	RAD
Number of supply fans	Nr	1	1	1	1	1	2
Fan diameter	mm	310	355	500	630	630	500
Type of exhaust fan	-	RAD	RAD	RAD	RAD	RAD	RAD
Number of exhaust fans	Nr	1	1	1	1	1	2
Standard power supply	V	400/3/50	400/3/50	400/3/50	400/3/50	400/3/50	400/3/50
Sound pressure level	(9) dB(A)	53	57	61	60	62	69
Minimum air flow	l/s	361	611	1278	2000	2638	3333
Minimum air flow	m ³ /h	1000	1600	3300	5200	7500	9500
Maximum air flow	(10) l/s	528	972	1944	2556	3194	3889
Maximum air flow	(10) m ³ /h	1900	3500	7000	9200	11500	14000

Notes

DB = dry bulb; WB = wet bulb; EERc = Thermodynamic efficiency of the system in cooling; COPc = Thermodynamic efficiency of the system in heating

- Outdoor air temperature: 35°C D.B./ 24°C W.B.; Exhaust air temperature: 26°C D.B. Supply air humidity ratio: 11g/kg; Supply air temperature: 24°C D.B.
- Outdoor air temperature: 7°C D.B./6.0°C W.B. Exhaust air temperature: 20°C D.B./ 12°C W.B.; Supply air temperature: 20°C D.B.
- Outdoor air temperature: 35°C D.B./ 24°C W.B.; Exhaust air temperature: 26°C D.B. Supply air humidity ratio: 11g/kg
- Outdoor air temperature: 7°C D.B./6.0°C W.B. Exhaust air temperature: 20°C D.B./ 12°C W.B.; Supply air temperature: 28°C D.B.

(5) Outdoor air temperature: 35°C D.B./ 24°C W.B.; Exhaust air temperature: 26°C D.B. Supply air temperature: 22°C D.B.

(6) Outdoor air temperature: 7°C D.B./6.0°C W.B. Exhaust air temperature: 20°C D.B./ 12°C W.B.; Supply air temperature: 16°C D.B.

(7) ROT = rotary compressor; SCROLL = scroll compressor

(8) RAD = radial fan

(9) The sound pressure level is referred at a distance of 1 m from the ducted unit surface operating in free field conditions. External static pressure 50 Pa. Please note that when the unit is installed in conditions different from nominal test conditions (e.g. near walls or obstacles in general), the sound levels may undergo substantial variations. Sound levels refer to unit with standard air flow rate

(10) In case of use with high air flow only the maximum flow rate value is possible



accessories

- ▶ **RECH** Hydronic recovery device for extended operating range
- ▶ **CCA** Copper/aluminium exchanger on exhaust air with acrylic lining
- ▶ **CEA** Copper/aluminium exchanger on outdoor air with acrylic lining
- ▶ **PVARC** Variable air flow on supply and exhaust with CO₂ probe
- ▶ **PVARCV** Variable air flow on supply and exhaust with CO₂+VOC probe
- ▶ **MHSEX** Immersed electrodes steam humidifying module
- ▶ **MCHSX** Steam-powered humidifying module
- ▶ **MOB** Serial port RS485 with Modbus protocol
- ▶ **LON** Serial port RS485 with LonWorks protocol
- ▶ **BACIP** BACnet-IP serial communication module
- ▶ **DESM** Smoke detector
- ▶ **AMRX** Rubber antivibration mounts
- ▶ **RSSX** Remote supply air sensor

Key to symbols:

- Accessories separately supplied

